



High Dynamic Range Receiver Parameters

The concept of a high-dynamic-range receiver implies more than an ability to detect, with low distortion, desired signals differing, in amplitude by as much as 90 or 100 dB. More importantly, the concept should indicate a high degree of immunity to spurious responses produced by nonlinear interaction of multiple high-level signals often far removed from the tuned frequency of the receiver.

The purpose of this article is to acquaint the reader with some of the parameters typically associated with frequency-synthesized VHF/UHF receivers designed for high-dynamic-range performance. The topics that will be discussed include noise figure, sensitivity, two-tone intermodulation distortion, third-order intercept point, spurious-free dynamic range, and internally generated spurious responses.

NOISE FIGURE - SENSITIVITY

Noise figure and sensitivity are two parameters normally associated with the ability of a receiver to detect very weak signals. The electronic circuitry in a receiver always adds a small amount of noise to an incoming signal in excess of that contributed by thermal effects. This circuit noise is normally the limiting factor in detecting low-level signals in the VHF/UHF spectrum.

The noise figure of a receiver is a very fundamental parameter and is basically a measure of the noise added by the receiver circuitry. An expression for defining the noise figure of an electronic device in terms of signal-to-noise ratios is given in Equation 1.

$$NF = 10 \log \left[\frac{S_i/N_i}{S_o/N_o} \right] \quad (1)$$

- where: NF = noise figure in dB
- S_i = signal power at device input
- N_i = noise power at device input
- S_o = signal power at device output
- N_o = noise power at device output

Sensitivity, on the other hand, is not a fundamental quantity. It is a measure of the receiver's ability to detect a signal of a given level, and is dependent on several factors, such as the type and degree of modulation used, the pre-detection (IF) or post-detection (video) bandwidths employed, the signal plus noise-to-noise ratio required at the detector output, as well as the receiver noise figure. A simple, though only approximate, expression showing the basic relationship of these factors to receiver sensitivity is given by Equation 2.

$$S = -174 \text{ dBm} \pm NF + 10 \log B + K_{sn} + K_m \quad (2)$$

Where: S = sensitivity in dBm
-174 dBm = thermal (KTB) noise power in a one-Hz bandwidth at room temperature

- NF = noise figure in dB
- B = pre-detection IF bandwidth in Hz (assumed to be twice the video or post-detection bandwidth)
- K_{sn} = desired (S+N)/N in dB of the detected signal
- K_m = a function of the modulation characteristics (dB)

This equation indicates that sensitivity improves (becomes more negative) with decreasing noise figure and/or decreasing IF bandwidth. VHF/UHF receivers frequently have noise figures in the range of 6 dB to 12 dB, whereas the IF bandwidths most commonly used, range from 10 kHz to over 5 MHz. Therefore, the sensitivity level of a typical receiver will be more heavily influenced by the IF bandwidth selected than the actual receiver noise figure.

To demonstrate the use of Equation 2 to compute sensitivity, assume a 50% amplitude modulated signal being detected by a receiver having a 10-dB noise figure and using a 10-kHz IF bandwidth. A 10-dB (signal plus noise)-to-noise ratio is required for the demodulated output.

Thus: NF = 10 dB

$10 \log B = 40 \text{ dB}$ for 10-kHz IF bandwidth

$$K_{sn} = 10 \text{ dB for the required } \frac{S+N}{N}$$

$$K_m = 6 \text{ dB for 50% AM}$$

Substituting these quantities into Equation 2 gives:

$$\begin{aligned}
 S &= -174 \text{ dBm} + 10 \text{ dB} + 40 \text{ dB} \\
 &\quad + 10 \text{ dB} + 6 \text{ dB} \\
 &= -108 \text{ dBm} \\
 &= 0.9 \text{ microvolts}
 \end{aligned}$$

INTERMODULATION DISTORTION -INTERCEPT POINT

All receivers employ RF-IF signal processing circuitry which is inherently non-linear; consequently, another very important factor in VHF/UHF receiver performance is two-tone intermodulation distortion. When two sufficiently strong, but unwanted signals are applied to the antenna input of a receiver they will mix in the RF stages to create spurious signals known as intermodulation products. If the frequency of one of these products is close to the receiver operating frequency, the product will be processed by the RF-IF and detector stages as though it were a real incoming signal of the same frequency. This problem is illustrated in Figure 1. Second-order and third-order intermodulation distortion are the most common types encountered, and the frequency relationships involved for these two cases are given by Equations 3 and 4.

$$f_1 \pm f_2 = f_t \quad (3)$$

2nd-order intermodulation distortion

$$2f_1 \pm f_2 = f_t \quad (4)$$

3rd-order intermodulation distortion

Where: f_1, f_2 = frequencies of strong undesired signals

f_t = frequency of inter-modulation product created at the receiver tuned frequency

Second-order, two-tone intermodulation dis-



ortion is not an uncommon problem, especially in a receiver having a broadband RF front end, but it can be minimized by use of a double-balanced mixer in the first converter stage plus use of a push-pull RF preamplifier. Also, with the addition of an RF preselector employing suboctave bandwidth bandpass filters (tunable or fixed), second-order interference can be reduced to an insignificant level. The suboctave preselector filter serves to attenuate strong signals, lying within a range of critical frequencies determined from Equation 3, which are capable of creating second-order products at the receiver tuned fre-

quency. This reduction in second-order interference by use of RF preselection is illustrated in Figure 2.

More troublesome and difficult to control is third-order, two-tone inter-modulation distortion, since RF preselection provides only a partial solution to the problem. This is due to the following distinctive property of third-order two-tone interference. Two strong undesired signals both falling within the passband of the preselector will produce the third-order products ($2f_1 - f_2$) or ($2f_2 - f_1$) one or both of which may also fall in-band.

Decreasing the preselector bandwidth will reduce the frequency range over which the receiver is susceptible to this type of interference. Unfortunately, due to considerations such as size, complexity, and insertion loss, a practical lower limit for the relative bandwidth of preselector filters used in general-coverage VHF/UHF receivers is around 20%. Therefore in a dense signal environment there is always the possibility that two strong signals will fall within the preselector passband and produce an undesired spurious response at the receiver tuned frequency. This situation is illustrated in Figure 3.

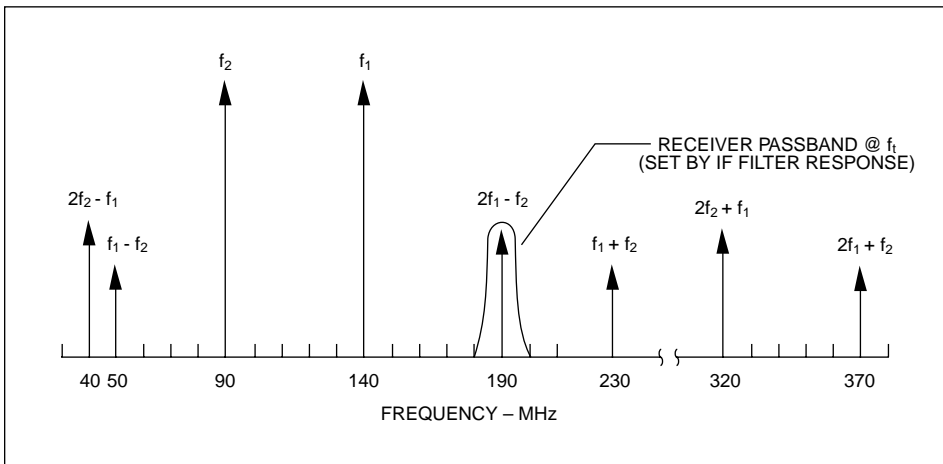

Figure 1. 2nd and 3rd order two-tone intermodulation products for two unwanted input signals at f_1 and f_2 with receiver tuned to f_i .

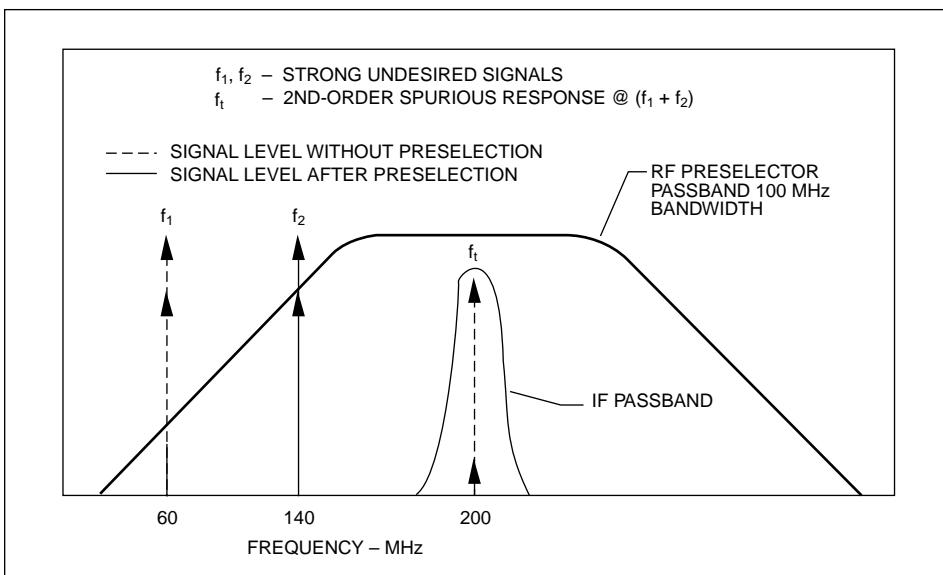

Figure 2. Reduction in 2nd-order interference using sub-octave preselector.

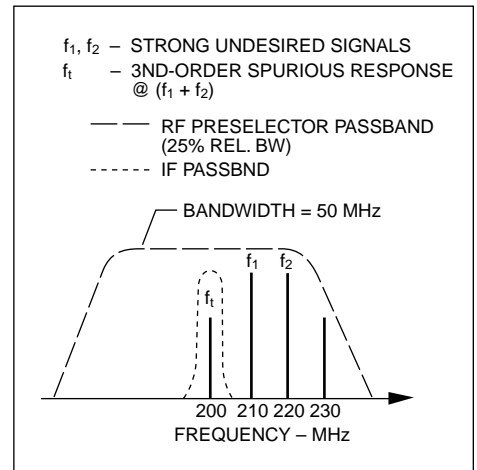

Figure 3. 3rd-order intermodulation interference caused by two strong inband signals.

Third-order intermodulation distortion is not limited to the RF front end of a receiver. The above description of the in-band characteristics of third-order interference is also applicable to the receiver IF stages. When the frequency spacing between strong incoming signals is small compared to the bandwidth of the first IF stage, then intermodulation distortion in the IF is likely to occur. Consequently, the problem must be minimized through proper circuit and system design, as well as component selection, for the overall RF-IF receiver chain.

Intermodulation performance is commonly tested by applying two signals of equal



power to the receiver input and then measuring the equivalent input level of the distortion product created at the receiver tuned frequency. The ratio in dB of the distortion product to the input level of the test signals is known as the inter-modulation ratio, and was frequently used in the past to specify intermodulation performance.

In recent years though, the intercept point concept has become a more popular method for characterizing the intermodulation distortion performance of many types of electronic equipment as well as radio receivers. The intercept-point method yields a single number, usually in dBm, which is independent of the input signal levels. The intercept-point concept for two-tone, third-order intermodulation is most easily understood by referring to Figure 4.

The curves in this figure show the typical input-output power relationships for the fundamental and third-order responses in a mildly non-linear system. The dashed line represents the variation in output power as a function of input power for the two fundamental input signals. Note that for small enough

input levels (ie. below compression) the curve is linear with a slope of unity indicating the output power of the fundamental changes on a dB-for-dB basis with the input power. The dotted line depicts the behavior of the output power of the intermodulation products as a function of the fundamental input power. Again the curve is linear for small enough input signals but has a slope of three. This slope indicates that the power in the third-order intermodulation products increases 3 dB for each dB increase in the input signal levels.

The fictitious extension of the linear portions of these two curves until they intersect establishes the intercept point. The input power level at which this point of intersection occurs is the third-order, two-tone intermodulation input intercept point of the system.

The intercept point of a system cannot be measured directly and therefore is computed from Equation 5.

$$IP = 1/2 (R_s) + P_{in} \quad (5)$$

Where: IP = 3rd-order input intercept point in dBm

R_s = relative suppression in dB of third-order products

P_{in} = input power level in dBm at which relative suppression is measured

The above relative suppression term R_s is the amount in dB by which the third-order intermodulation products are suppressed below the fundamental responses when measured at the system output, and is shown graphically in Figure 4 as the vertical difference between the two curves. The typical test setup used for evaluating two-tone intermodulation performance and the method for determining R_s is shown in the simplified illustrations of Figure 5.

Another important relationship, involving intercept point, which can be used to determine the equivalent input level of intermodulation products is given by Equation 5a.

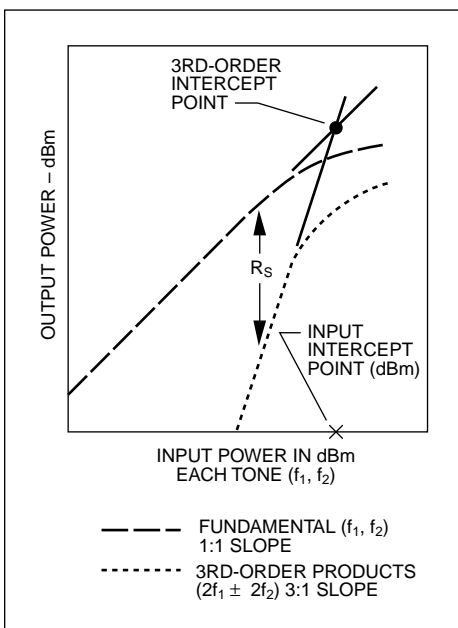

Figure 4. Input-output power relationship for two-tone 3rd-order intermodulation distortion.

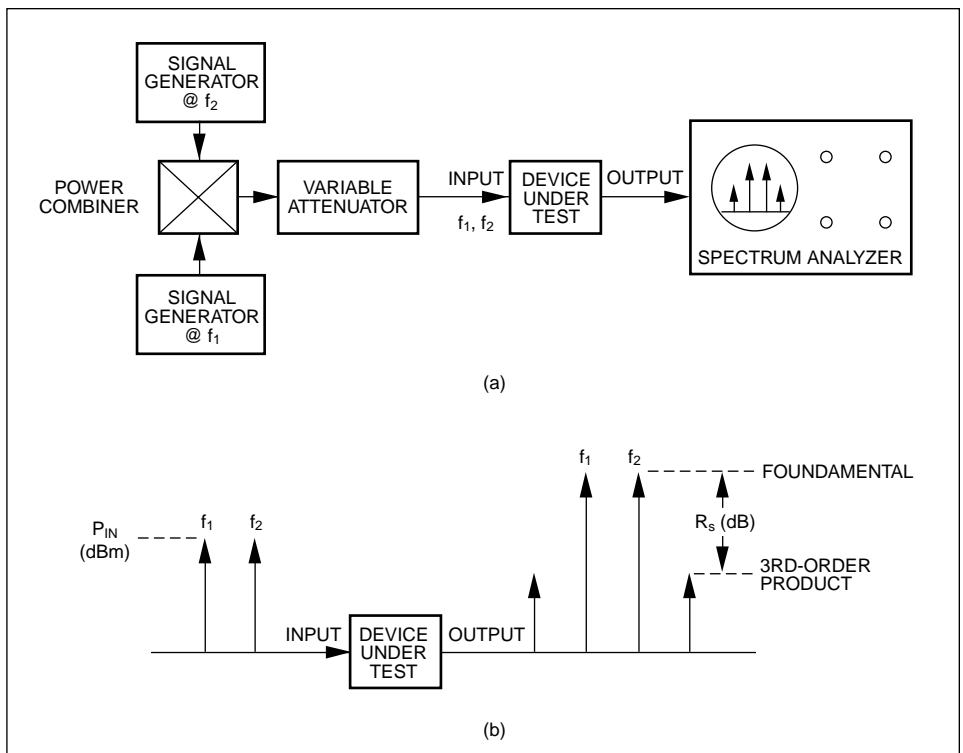

Figure 5. (a) Test setup for two-tone intermodulation distortion. (b) Measurement of R_s term used in calculation of intercept point.



IM = 3(P_{in}) - 2(IP) (5a)

Where: IM = equivalent input power in dBm of 3rd-order intermodulation products

IP = 3rd-order input intercept point in dBm

The higher the third-order intercept point of a receiver, the less susceptible it will be to spurious responses caused by strong multiple in-band signals. Unfortunately, the desire for a high intercept-point receiver is often not compatible with the simultaneous requirement for low noise figure. Compromises usually must be made when specifying both the receiver noise figure and its third-order intercept point.

As a general rule of thumb, a receiver designed for high intercept-point performance will employ RF-IF amplifier stages and double-balanced mixers all having high 1 dB compression points. These power amplifier stages generally have higher noise figures and consume more supply power than small-signal amplifiers. High-power mixers require large local oscillator drive levels which, in turn, can result in higher LO radiation levels and larger internally-generated spurious responses, as well as more power consumption. Thus, the requirement for an extremely high intercept-point receiver can create a multitude of design problems and result in very expensive equipment.

SPURIOUS-FREE DYNAMIC RANGE

Another parameter frequently used to characterize receiver performance is spurious-free dynamic range. The expression "spurious-free dynamic range" is used here to mean that portion of the total dynamic range where there are no 3rd order spurious responses exceeding the noise floor by 3 dB when two equal-power input signals are applied. The dynamic range of a receiver is the range of input signal levels over which the receiver is usable. Various criteria have been used to

define the upper and lower limits for this usable range. One criterion often used to establish the lower limit of the dynamic range is called the minimum detectable signal and is defined as a signal 3 dB greater than the equivalent noise power for a given IF bandwidth. The minimum detectable signal (MDS) is relative to receiver noise figure and IF bandwidth by Equation 6.

P_L = MDS = -171 dBm + NF + 10 log B (6)

Where: P_L = lower power limit of dynamic range in dBm

MDS = minimum detectable signal in dBm

NF = noise figure in dB

B = IF bandwidth in Hz

The upper limit for spurious-free dynamic range (SFDR) is typically set by the level of two equal input signals necessary to create a third-order intermodulation product equivalent to the minimum detectable signal.

Through use of Equation 5a, this definition can be expressed by Equation 7.

MDS = 3(P_u) - 2(IP) (7)

Where: P_u = upper power limit of spurious-free dynamic range in dBm

IP = receiver 3rd-order input intercept point in dBm

The upper power limit is now given by Equation 8.

P_u = 1/3 (MDS + 2IP) = 1/3 (-171 dBm + NF + 10 log B) + 2/3 (IP) (8)

Using the above expressions for P_L and P_u, the spurious-free dynamic range can now be found from Equation 9.

SFDR = P_u - P_L = 1/3 (MDS + 2IP) - MDS = 2/3 (IP - MDS) = 2/3 (IP - NF - 10 log B + 171 dBm) (9)

where SFDR = spurious-free dynamic range in dBm

Thus, it is seen that spurious-free dynamic

range is directly proportional to intercept point, but inversely proportional to noise figure and IF bandwidth. In other words, the dynamic range increases with lower noise figures and narrower IF bandwidths as well as for higher intercept points.

As an example of computing the spurious-free dynamic range for a typical high-performance receiver, assume a noise figure of 10 dB, an IF bandwidth of 10 kHz, and an input intercept point of -5 dBm. Substituting these quantities into Equation 9 yields:

SFDR = 2/3 (-5 dBm - 10 dB - 40 dB + 171 dBm) = 77.3 dB

INTERNALLY GENERATED SPURIOUS RESPONSES

In a frequency-synthesized, general-coverage VHF/UHF receiver there are numerous mechanisms by which spurious responses can be generated within the receiver, even though no input signals are present at the antenna terminals. Some of these responses are due to mixing of harmonics of the various local oscillators necessary in dual and triple conversion designs. Others are related to synthesizer operation. Extreme care must be exercised in both the electrical and mechanical designs of the receiver to minimize these responses.

Although internally generated spurious responses are not directly related to the strong signal-handling ability of a receiver, they can degrade the utility of a receiver that otherwise exhibits high-dynamic-range qualities. These responses, as well as being nuisance signals, may also obscure weak signals of interest. In other words, the signal-detection ability or sensitivity of the receiver may be limited by the level of these spurious responses rather than by circuit noise. To prevent this possibility, the equivalent input level of internally generated responses should be comparable to the minimum detectable signal defined earlier. There is little value in requiring the spurious responses to be much lower than this level.



Thus, a reasonable lower limit for an internal spurious specification can be related to the receiver noise figure and IF bandwidth by Equation 10.

$$P_s = MDS = -171 \text{ dBm} + NF + 10 \log B$$

Where: P_s = lower limit for spurious specification in dBm

It is interesting to note that standard definitions for dynamic range, such as the one previously used for SFDR, typically use a lower limit established by noise considerations. A functional lower limit could have been set by

the level of the internally generated spurious responses, provided they exceeded the MDS of the receiver.

CONCLUSION

VHF/UHF receivers used for signal reception should have high sensitivity, yet be as free as possible from interference caused by unwanted signals. Manufacturers have, for years, routinely addressed the problems of IF selectivity, IF rejection, and image rejection, which are related to forms of linear interference. With increased activity in the VHF/UHF spectrum,

both receiver manufacturers and operators are also becoming more concerned with the problems of nonlinear interference.

Consequently, new receiver designs have begun to stress high-dynamic-range performance.

This article has reviewed several receiver parameters and their interrelationships that are critical to high-dynamic-range performance. The intent of the article has been to provide the reader with an appreciation of the need for high-dynamic-range signal-handling in a VHF/UHF receiver.